

NAYPUNYAM FIESTA -2016

ZONAL COMPETITION

TRADE : WELDER

MARKS: 200

TIME: 4 HRS

1. Butt weld V joint, over head position (4G) without backing

100 marks

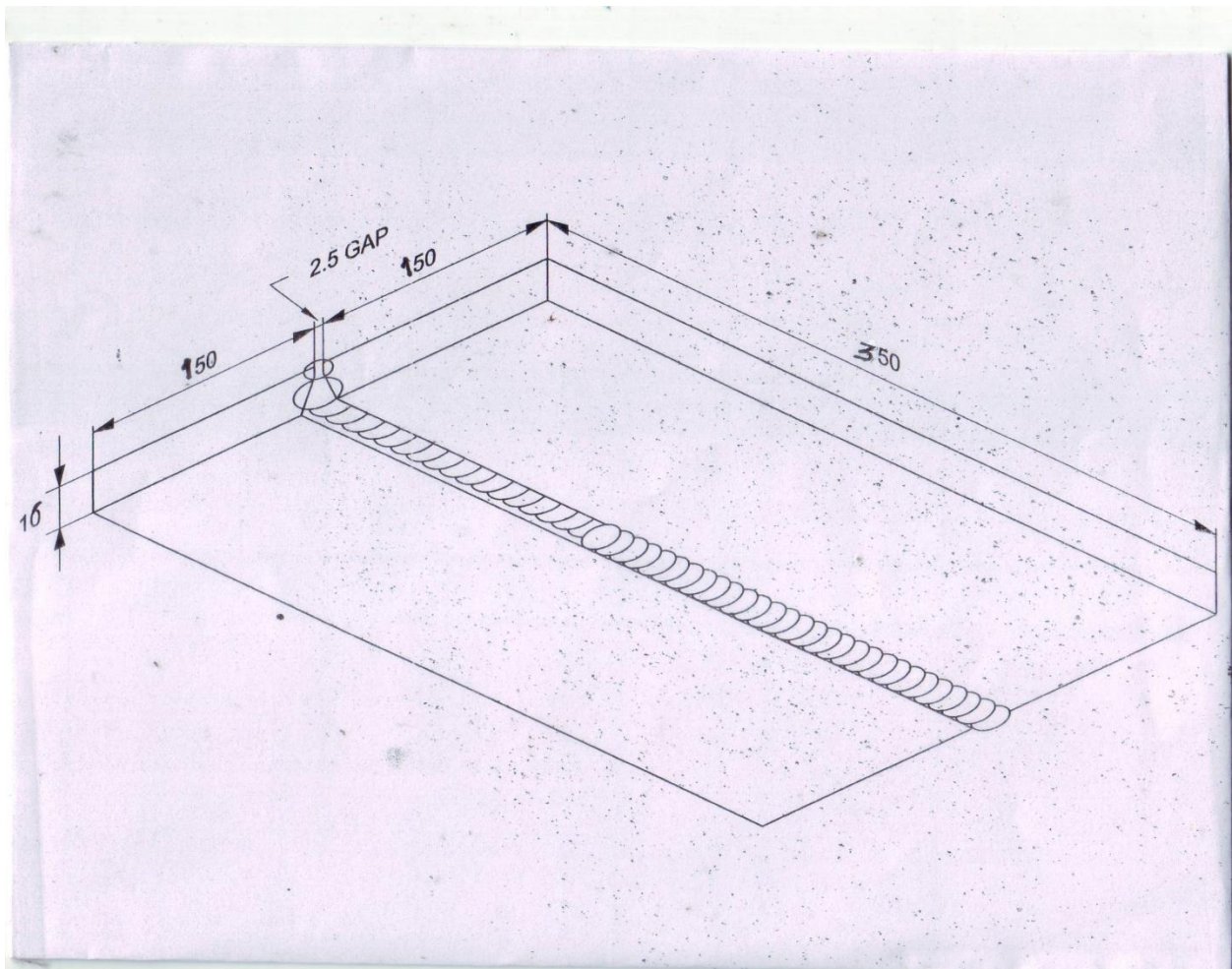

ALL DIMENSIONS ARE IN mm

A. Materials required

1. Carbon steel plate 350x150x16 mm- 2 nos
2. MS electrode E7018, dia 2.5 mm
3. MS electrode E7018, dia 3.15 mm
4. Grinding wheel 4" & 7"

A. Tools and equipments required

1. Welding rectifier set 300 A
2. Angle gauge
3. Angle grinder 4" & 7"
4. Flat file 300 mm
5. Wire brush
6. Chipping hammer
7. Steel rule 300 mm
8. Flat tongs
9. Hammer
10. Electrode oven
11. Safety apparels

2. Butt joint on pipe 50mm O.D, 8mm WT ,5G position (fixed)

100marks

- a. Root run to be done by TIG welding process
- b. Fill pass & cap pass to be done by ARC welding process

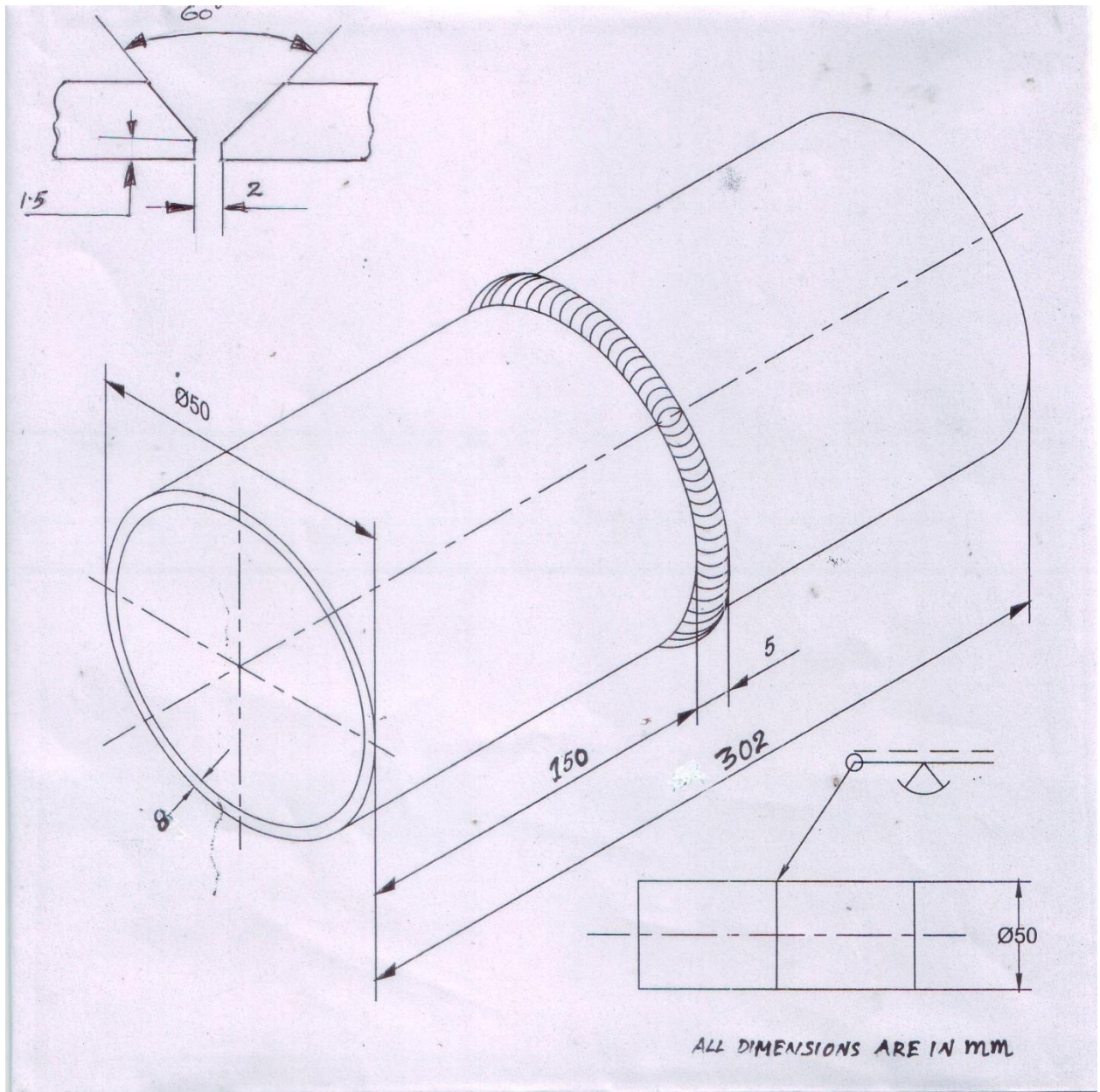

A. Materials required

1. Carbon steel pipe dia 50x150x8mm – 2 nos
2. MS electrode E7018, dia 2.5 mm
3. MS electrode E7018, dia 3.15 mm
4. Thoriated Tungsten electrode dia 2.5 mm, 3mm

5. Al. Nozzle No.4,5,6
6. Collet 2.5mm,3 mm
7. Collet body 2.5mm,3 mm
8. TIG filler rod 70 S2,dia 2.5 mm
9. Grinding wheel 4" &7"

B. Tools and equipments required

- 1.Welding rectifier set 300 A
- 2.TIG Welding set 300 A
- 3.Angle gauge
- 4.Angle grinder 4" &7"
12. Flat file 300 mm
- 5.Wire brush
- 6.Chipping hammer
- 7.Steel rule 300 mm
- 8.Flat tongs
- 9.Hammer
- 10.Electode oven
- 11.Safety apparels